

# ARIZONA HOME CARE/PATIENT CARE INFUSION PHARMACY

## HOME INOTROPIC MEDICATION ADMINISTRATION PATIENT EDUCATION TOOL

Name \_\_\_\_\_

Nurse \_\_\_\_\_

Pharmacy Contact \_\_\_\_\_

Your doctor has ordered home inotropic medications to be given through your PICC catheter. This medication is used in congestive heart failure.

**Your PICC** \_\_\_\_\_

Date Placed \_\_\_\_\_ Length to hub \_\_\_\_\_

**Use only one lumen of your PICC for your home inotrope medication infusion.**

- The lumen used for the medication is the \_\_\_\_\_ lumen.
  - Do not flush the \_\_\_\_\_ lumen unless instructed by your nurse.
- The \_\_\_\_\_ lumen will be used for blood draws and other medications needed.

Flush the \_\_\_\_\_ lumen  daily  twice a day  weekly  
with 10 ml Normal Saline when not in use.

Flush \_\_\_\_\_ lumen with \_\_\_\_\_ ml Heparin after the Normal Saline flush.

**Medication** \_\_\_\_\_

**Continuous Dose/Rate** \_\_\_\_\_

**Time of Daily Bag Change** \_\_\_\_\_

**ARIZONA HOME CARE 602-252-5000 24 HOURS/DAY**

# GENERAL INFORMATION ON CARING FOR YOUR PICC AT HOME

## What is a PICC line?

A PICC is a catheter that is placed in a vein by your nurse or doctor to give your IV medications or fluids.

- The end of the PICC is in the largest vein by your heart.
- A PICC that has the end in the shoulder area is called a Midline.
- There is no needle or wire in your PICC.

## Infection Control

Aseptic or sterile technique is used when caring for your central line and giving your IV medications. Keep your hands and surroundings clean to prevent infection.

- Always wash your hands with antibacterial soap for 30-60 seconds before caring for your central line or giving IV medications and again if you are interrupted doing the care.
- Dry your hands with paper towels or a clean towel.
- Prepare a clean area when caring for your PICC or giving IV meds.
- Never touch the end of the syringe, IV tubing or IV bag openings with your hands or unsterile objects.
- Use red caps to protect the end of IV tubing between uses.
- Keep your IV supplies away from pets and small children.



## Safety and Organization

Keeping organized is very important when doing infusions in the home.

- Organize your supplies for your infusion. Notify the pharmacy if you need extra supplies or need a replacement for an IV medication that you needed to discard.
- Use the yellow chemotherapy box that was provided for you for your used chemotherapy tubing, needles and syringes. Keep this away from children and pets.
  - Give to your nurse or notify the pharmacy when it is  $\frac{3}{4}$  full.
- Put used supplies in a separate trash bag and double bag it when throwing it away.



## Always protect your central line

- Keep your central line dressing clean and dry at all times. Moisture or sweat under the dressing is a breeding ground for germs that can cause an infection in your central line and blood.
- When showering cover the exposed central line with a plastic bag sealed with tape or purchase a DRYPRO PICC PROTECTOR. Ask your nurse for more information.
- Do not swim with your central line.
- Keep a clean netting cover provided by Arizona Home Care over your PICC dressing.
- Be aware of getting the tubing tangled in clothes, bedding and blankets.
- Do not lift anything heavy with your PICC arm to avoid it accidentally coming out of place.

# ABOUT YOUR PICC LINE

## How often will my PICC dressing need changed?

The PICC dressing must remain clean and dry to avoid infection or coming out of place.

The PICC dressing will need to be changed by your Home Care Agency:

- Every 7 days if you have a clear dressing on the PICC.
- Every 2 days if you have a gauze dressing or gauze/clear dressing.
- If the dressing becomes wet, sweaty, soiled, or starts to come off.



## What is on the end of my PICC line?

The end of the PICC is protected by a special cap.

- The cap must stay on the PICC at all times to prevent infection.
- Always scrub the cap for 10-15 seconds with an alcohol wipe whenever connecting a syringe or tubing.
- Use a new alcohol wipe each time your scrub.
- If the cap comes off accidentally when removing the syringe or tubing, twist on a new clean cap and call Arizona Home Care to have the nurse assist.

## Do I need heparin when I am flushing my PICC?

- Some PICCs require heparin to keep the PICC from clotting. Other PICCs do not.
- Flush your PICC line as you have been instructed by your Home Health Nurse.

## Can I do my PICC care or give my medications/fluids anywhere?

### Your PICC care and infusion should be done in a clean, safe place.

- Always clean your work surface with alcohol or antibacterial wipes or lay clean paper towels.
- Do not eat or drink while preparing your supplies and doing your care or medication/fluid administration.
- Do not smoke while preparing your supplies and doing your care or medication/fluid administration.
- Keep pets and small children away from your work area to avoid possible contamination.
- Some insurances require that you are homebound to pay for nursing care and infusion supplies in the home.
  - Notify your nurse if you are planning to do your care outside your home.
  - If going back to work, your nurse may be able to make arrangements to assist you at your workplace with your employer's approval.

# ABOUT YOUR MEDICATIONS

## Where do I store my medications/IV fluids?

- Your Home Health nurse or pharmacy will instruct you on how to store your medication.
- If your medications need to be refrigerated
  - Keep it in a clean, top shelf.
- If your medications can be stored without refrigeration
  - Store in a clean, dry area
  - Keep out of reach from children and pets.

## Where do I get my medications/IV fluids?

- Your medications have been prepared by Patient Care Infusion Pharmacy at Arizona Home Care.
- The Pharmacists and Pharmacy technicians prepare the medications using sterile technique.

## Before giving your medications/IV fluids

Always read your medication label before giving and check the following:

- Correct name of patient
- Correct dose
- Correct medication
- Expiration date
- Directions for use

## Know what the medication is for and what the side effects are.

The pharmacy has provided you with information on your IV medication.

- Keep this information sheet in your brown start of care folder for future needs.
- Notify Arizona Home Care immediately if you are having side effects from your medication or problems when you take your fluids.

## Your IV medication is:

Medication: \_\_\_\_\_

Purpose: \_\_\_\_\_

Side effects: \_\_\_\_\_

\_\_\_\_\_

\_\_\_\_\_

\_\_\_\_\_

## FLUSHING YOUR PICC LINE

### Your PICC line has 2 lumens or hubs.

Do not flush the \_\_\_\_\_ lumen unless instructed by your nurse.

- This lumen is only for your inotrope medication.
- Flushing this line will give you a larger dose of your medication if you were to flush with the saline flush.
- Flushing this line will also fill the lumen with saline. Depending on the rate of your infusion it may take an extended time for the pump to fill the saline filled lumen with the inotropic medication.

### Follow the procedure below to flush the \_\_\_\_\_ lumen.

1. Prepare your work area by laying down clean paper towels or clean the surface with alcohol or antibacterial wipes.
2. Assemble Supplies:
  - Gloves
  - 1- 10ml Normal Saline in a syringe
  - 1- 5ml Heparin Saline in a syringe (not used in all PICCs)
  - Alcohol swabs \*at least 4
3. Wash your hands for 30-60 seconds with antibacterial soap.
  - Dry with paper towels or a clean unused towel.
4. Scrub the cap on the end of the PICC with the alcohol swab for 10-15 seconds.

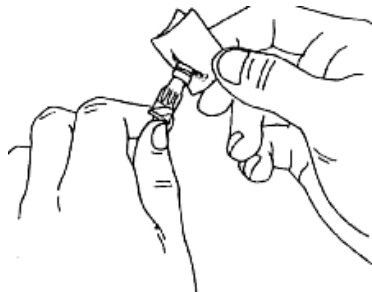

## FLUSHING YOUR PICC LINE – CONTINUED

5. Connect the 10 ml Normal Saline syringe to the PICC cap.
  - Push 10 ml Normal Saline into the PICC using a push-pause motion.
  - Disconnect the syringe from the PICC.
  - CAUTION to remove air bubbles before connecting the syringe.
  - Leave a very small amount of saline in the bottom of the syringe.

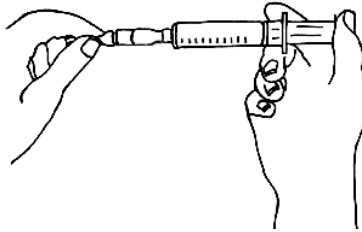

### For PICCs that Require Heparin complete the next two steps:

8. Scrub the PICC cap again with a new alcohol swab for 10-15 seconds.

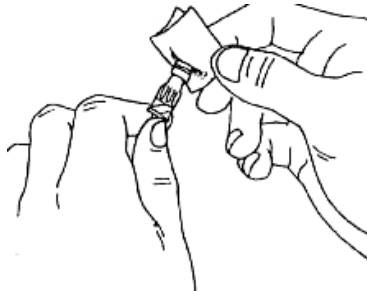

9. Remove any air bubbles from the Heparin syringe and connect the syringe to the PICC cap.
  - Push 5ml of Heparin from the syringe into the PICC using a push-pause motion.
  - Disconnect the syringe from the PICC.

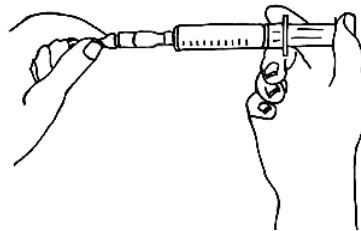

# BASIC CARE INFORMATION FOR YOUR HOME INOTROPIC INFUSIONS

## General instructions

- Excellent handwashing and aseptic technique are always used when handling the IV supplies or the PICC.
- Check your pump display screen throughout the day to make sure the pump is running.
- There should always be two working pumps available at all times whether at home or away.
- Extra batteries must be available at all times.
  - Notify AZHC if more batteries are needed.
- If your PICC line comes out call 911 to transport you to the closest emergency room.
- Have someone trained as a back-up to assist you in your care.

## Your IV Medication Bags

- There should always be a spare IV bag with the inotropic medication available in the home.
- IV medication bags must be changed daily.
- IV medication bags are stored in the refrigerator until use and taken out 30-60 minutes prior to use.

## Your IV Tubing

- IV tubing is changed on **Monday, Wednesday and Friday**.
- When changing tubing, always use a new IV medication bag.
- If the tubing becomes contaminated it should be thrown away and a new one used.
- Use the “Switchover” technique for changing IV tubing.
  - Always prime the new tubing on the pump not currently being used to infuse the medication.
  - Then disconnect the old tubing and connect the new tubing.
  - Do not interrupt your infusion of inotropic medication to prepare new tubing.

## General Pump Safety Guidelines

- Do not get pump wet or immerse in water.
- Protect pump from being dropped or tossed to avoid impact. If the pump is accidentally dropped or mishandled, check the pump programming to make sure it has not been damaged.
- Only use an AC Adaptor provided by Arizona Home Care that is specifically for the Gemstar pump.

## CHANGING THE IV MEDICATION BAG AND TUBING

Follow the procedure below to change your IV medication bag and or IV tubing.

- If you are only changing the IV medication bag, complete steps 1-6 then reprogram the pump for a new container as instructed.

1. Prepare your work area by laying down clean paper towels or clean the surface with alcohol or antibacterial wipes.
2. Assemble Supplies:
  - Gloves
  - 1- 10ml Normal Saline in a syringe
  - 1- 5ml Heparin Saline in a syringe (not used in all PICCs)
  - Alcohol swabs \*at least 4
3. Wash your hands for 30-60 seconds with antibacterial soap.
  - Dry with paper towels or a clean unused towel.
4. Push down on the flow stop to close the cassette on the new Gemstar pump tubing.



5. Remove the protective plastic tab off the IV medication bag port/opening.
  - If using a fannypack or backpack to hold the IV medication bag gently squeeze or roll the container to remove air from the container.
    - This is very important if using a backpack or fanny pack to avoid air in the tubing alarms.
  - Do not touch the end of the IV medication bag port/opening. This is sterile.
  - Caution not to spill the IV fluids out of the bag.

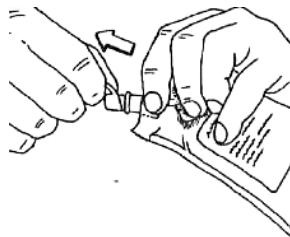

6. Hold the container with the port/opening toward the ceiling and insert the spike from the IV tubing.

- Do not touch the spike of the tubing. This is sterile.
- Twist the spike as far as it will go into the IV bag port/opening.

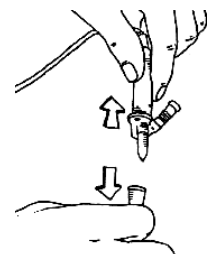



## CHANGING THE IV MEDICATION BAG AND TUBING- CONTINUED

7. Load the cassette.

- The white knob of the cassette should be “down and in” touching the pump when loading the cassette.

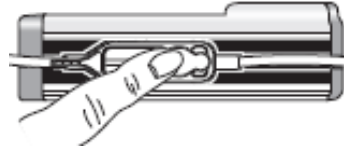

8. Press [ON/OFF] to turn the pump on.

If the pump screen says Resume Program, press [YES/ENTER]. Press the Arrow Down key until the program review is complete. Then press [YES/ENTER].

9. Press [PURGE].



10. The pump displays PRIME THE SET? Press [YES/ENTER].

- The pump will then display a message for a few seconds to disconnect the patient from the IV tubing.
- Do not press the [PURGE] button while this is on the display or the pump will alarm.

11. Press and hold [PURGE] until the IV tubing is filled to the end with fluid and is free of air bubbles.



12. Press [YES/ENTER] when the priming is complete. Press [NO] if you need to continue to prime the tubing.

13. Press the [START] key on the pump with the newly primed tubing.



## CHANGING THE IV MEDICATION BAG AND TUBING- CONTINUED

14. Disconnect the old tubing from the PICC cap- **do not stop the infusion.**

15. Scrub the PICC cap again with a new alcohol swab for 10-15 seconds.



16. Connect the new tubing to the PICC cap. Do not touch the end of the tubing or cap. This is sterile.

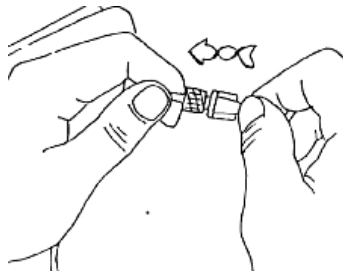

**16. Check the pump display to make sure that it is running.**

### Reprogramming the Pump When Changing the IV Bag

1. When changing the IV bag daily the pump must be programmed for a new container.
2. If the pump is not reprogrammed, it will alarm "Empty Container" even though the container is not empty.
3. To reprogram for a new container do the following steps after the container is changed. Press the Display Keys in the following order:

1. **[STOP].**
2. **[CHANGE].**
3. **[1] (NEW CONTAINER).**
4. **[START].**

# CHANGING THE BATTERIES

## General instructions

- Batteries are generally changed every 20-24 hours.
- Use the batteries provided by Arizona Home Care.
- Do not use rechargeable batteries.
- Always have extra batteries with you in case there is a low battery alarm.

## How to Change the Batteries

1. Flip up the tab of the battery door on the bottom of the pump.
2. Hold onto the tab and turn the battery door to the counterclockwise/left to unlatch.
3. Pull the door free and remove the old batteries.
4. Install two fresh, disposable AA batteries into the battery compartment.
  - Look at the positive/negative symbols and insert as shown.
5. Return the battery door to the battery compartment.
6. Turn the battery door to the clock-wise/right securing the door under the slot.
7. Flip down the tab of the battery door to lock in place.

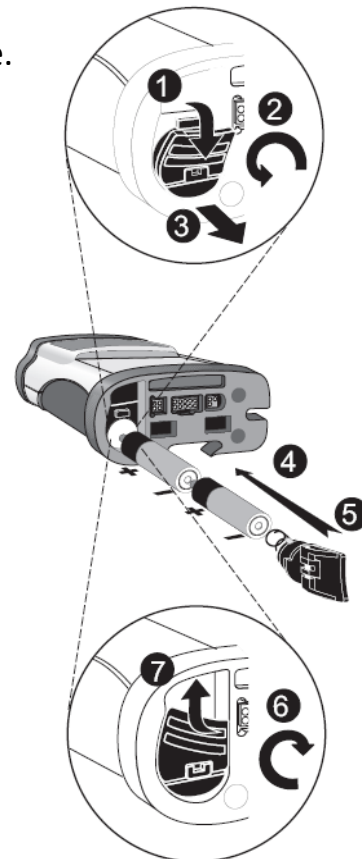

**Positive (+) or knobbed side of the battery goes towards the pump when inserting batteries.**

# TROUBLESHOOTING ALARMS

## SILENCE

1. Press the [SILENCE] key. Look at the alarm message on the screen.
2. Press the [STOP] key to stop the infusion.
3. Correct the reason for the alarm.
4. Press the [START] key to restart the infusion.

## END OF INFUSION

The pump has given the medications or IV fluids as programmed and the infusion is complete.

Note: If the pump is programmed for “KVO” it will continue to give the IV fluids at 2ml/hour after the infusion of medications or IV fluids is completed.

1. If the KVO has NOT been programmed in the pump settings:
  - Press [SILENCE] to quiet the alarm for 2 minutes.
  - Press [STOP] to stop the pump and clear the alarm.
2. If KVO is selected:
  - The pump sounds 5 beeps approximately 15 minutes apart while running.
  - Press [STOP] to stop the pump and clear the alarm.

## LOW BATTERIES

The batteries are too low to use on the pump and need to be changed.

The pump will alarm when you have only 30 minutes left of battery power.

1. Press [SILENCE] to silence the alarm for 1 minute.
2. Press [STOP] to stop the pump.
3. Change the batteries.
4. Press [START] to restart the pump.

## CHECK CASSETTE

The cassette is not loaded correctly in the pump or has become dislodged.

1. Press [SILENCE] to silence the alarm for 1 minute.
2. Press [STOP] to stop the pump.
3. Check the cassette to make sure it is pressed in correctly and “clicks” in place.
  - Take out the cassette and reload if necessary.
4. Press [START] to restart the pump.

## Notes

---

## TAKING CARE OF YOURSELF DAILY IN THE HOME

**Monitoring your health is a critical for safe and successful home infusion.  
Refer to the specific instructions given by your doctor or hospital.**

1. Monitor your weight every day - **Same time, Same place**
  - Report 2 lb increase in 24 hours or 5 lb increase in one week.
  - Don't forget to address weight reduction
  - Record each day on your Daily Tracking Log.
2. Monitor your blood pressure daily
  - Review with your home care nurse how to do.
  - Take your blood pressure in your arm without the PICC line.
  - Record your blood pressure each day in your Daily Tracking Log.
3. Record your heart rate and temperature daily.
4. Monitor your total salt intake daily.
  - Limit to 2grams per day maximum.
  - Use daily chart to help you to track your progress.
5. Maintain an Angina or Symptom Log daily.
6. Monitor your blood sugar levels if you are a diabetic or have been told to track by your physician.
  - Record your blood sugars of your Daily Tracking Log
7. It is very common to experience feelings of anxiety or depression.
  - Be aware of changes in your feelings or moods.
  - Review the handout on Managing Feelings
8. Follow the exercise program given by your doctor each day.
  - Do not attempt exercises at home that have not been cleared by your doctor.
  - If you experience any chest pains or symptoms with exercise, STOP.

**Ask your nurse for more information.**

**Go to the American Heart Association website [www.hearthub.org](http://www.hearthub.org) for more information on taking care of your heart.**



# BLOOD PRESSURE TRACKER – PRINTABLE TRACKER

## INSTRUCTIONS:

- Take your pressure at the same time each day, such as morning or evening, or as your healthcare professional recommends.
- Sit with your back straight and supported and your feet flat on the floor.
- Your arm should be supported on a flat surface with the upper arm at heart level.
- Make sure the middle of the cuff is placed directly over your brachial artery. Refer to the Instructions page of this tracker for a picture, or check your monitor's instructions, or have your healthcare provider show you how.
- Each time you measure, take two or three readings, one minute apart, and record all the results.

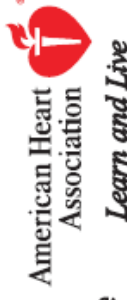

NAME: \_\_\_\_\_

MY BLOOD PRESSURE TARGET GOAL IS: \_\_\_\_\_ / \_\_\_\_\_ mm Hg

DATE/TIME	READING 1		READING 2		READING 3		COMMENTS
	BLOOD PRESSURE	HEART RATE (PULSE)	BLOOD PRESSURE	HEART RATE (PULSE)	BLOOD PRESSURE	HEART RATE (PULSE)	
1/1/08 8:00pm	132/85 mm Hg	81 Beats Per Min.	130/80 mm Hg	70 Beats Per Min.	126/80 mm Hg	72 Beats Per Min.	at pharmacy
	/		/		/		
	/		/		/		
	/		/		/		
	/		/		/		
	/		/		/		
	/		/		/		
	/		/		/		
	/		/		/		
	/		/		/		
	/		/		/		
	/		/		/		
	/		/		/		
	/		/		/		
	/		/		/		
	/		/		/		
	/		/		/		
	/		/		/		
	/		/		/		

Blood pressure higher than 180/110 is an emergency. Call 9-1-1 immediately. If 9-1-1 is not available to you, have someone drive you to the nearest emergency facility immediately.

**Symptom Tracker:** If you have any of the symptoms listed below, circle the number that describes best how you feel. For instance, if you are a little short of breath, circle the number 1. If you are very short of breath, circle the number 5. If you do not have a symptom that is listed, do not circle a number.

	Monday date:	Tuesday date:	Wednesday date:	Thursday date:	Friday date:	Saturday date:	Sunday date:
Weight and time of day							
Shortness of breath	1 2 3 4 5	1 2 3 4 5	1 2 3 4 5	1 2 3 4 5	1 2 3 4 5	1 2 3 4 5	1 2 3 4 5
Frequent coughing	1 2 3 4 5	1 2 3 4 5	1 2 3 4 5	1 2 3 4 5	1 2 3 4 5	1 2 3 4 5	1 2 3 4 5
Fast heart rate or heavy heart beat	1 2 3 4 5	1 2 3 4 5	1 2 3 4 5	1 2 3 4 5	1 2 3 4 5	1 2 3 4 5	1 2 3 4 5
Tired/weak	1 2 3 4 5	1 2 3 4 5	1 2 3 4 5	1 2 3 4 5	1 2 3 4 5	1 2 3 4 5	1 2 3 4 5
Swollen ankles	1 2 3 4 5	1 2 3 4 5	1 2 3 4 5	1 2 3 4 5	1 2 3 4 5	1 2 3 4 5	1 2 3 4 5
Swollen legs	1 2 3 4 5	1 2 3 4 5	1 2 3 4 5	1 2 3 4 5	1 2 3 4 5	1 2 3 4 5	1 2 3 4 5
Swollen belly	1 2 3 4 5	1 2 3 4 5	1 2 3 4 5	1 2 3 4 5	1 2 3 4 5	1 2 3 4 5	1 2 3 4 5
Swollen lower back	1 2 3 4 5	1 2 3 4 5	1 2 3 4 5	1 2 3 4 5	1 2 3 4 5	1 2 3 4 5	1 2 3 4 5
Loss of appetite	1 2 3 4 5	1 2 3 4 5	1 2 3 4 5	1 2 3 4 5	1 2 3 4 5	1 2 3 4 5	1 2 3 4 5
Weight gain	1 2 3 4 5	1 2 3 4 5	1 2 3 4 5	1 2 3 4 5	1 2 3 4 5	1 2 3 4 5	1 2 3 4 5

Use this space to write notes, or to record any other symptoms you may be having.

.....

.....

.....

Please turn this page over to find the Sodium Tracker for each day.

## WHEN TO CALL

**Call Arizona Home Care or \_\_\_\_\_:**

1. The PICC is hard to flush.
  - There is pain when flushing the PICC or giving the medication.
  - A red streak is visible from the PICC insertion site along the vein
  - The PICC site has blood, drainage or is wet.
  - Skin around the PICC site becomes
    - Sore to touch
    - Swollen
    - Hard
    - Red or has a change in color
2. If your daily monitoring of weight, blood pressure, heart rate, blood sugar or temperature is above or below what the doctor has given your normal range.
3. Questions on how to care for your PICC.
4. Questions or problems with your pump.
5. If you need more supplies for your home infusion.



### **Call Your Doctor**

1. If you are experiencing side-effects from the medication.
2. If you have a worsening or increase in symptoms.
3. If you have a fever, chills, or signs of an illness.
4. To schedule your follow-up appointments.
5. With questions related to your lab results.
6. With questions related to your procedures or tests.

### **Call 911**

1. If your PICC line becomes dislodged or broken.
2. If you have difficulty breathing.
2. If you have increased chest pain.
3. If you have a defibrillator that is activated.



# QUICK REFERENCE FOR YOUR HOME INOTROPE CARE

- Change IV bags of inotropic medication daily.
- Change IV tubing every Monday, Wednesday and Friday and as needed.
- Flush the \_\_\_\_\_ lumen  daily  twice a day  weekly
- Monitor the following and record in your person log daily:
  - DAILY WEIGHT ON THE SAME SCALE, SAME TIME OF DAY.  
*CALL NURSE IF WEIGHT IS INCREASED 2 POUNDS IN ONE DAY OR 5 POUNDS IN A WEEK.*
  - DAILY BLOOD PRESSURE CHECK. CALL NURSE IF BP > \_\_\_\_\_ OR < \_\_\_\_\_.
  - DAILY PULSE CHECK. CALL NURSE IF PULSE > \_\_\_\_\_ OR < \_\_\_\_\_.
  - TEMPERATURE. CALL NURSE IF TEMPERATURE > \_\_\_\_\_.
  - SODIUM INTAKE IN YOUR DAILY DIET. MAXIMUM OF 2 GRAMS.
  - OTHER \_\_\_\_\_.

